

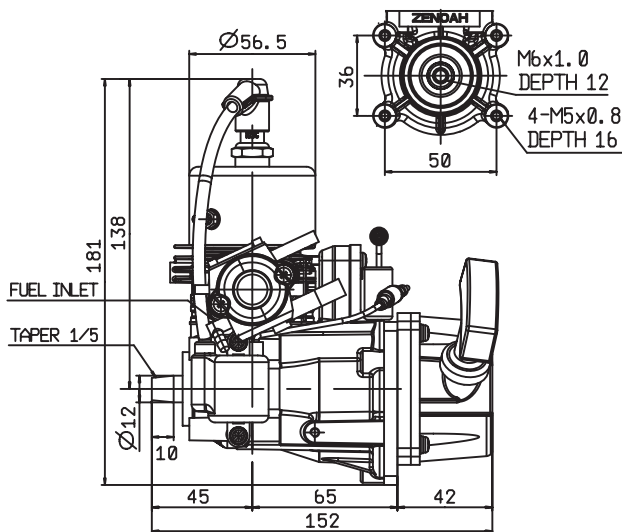

114 06 37-26 (1808)

OWNER'S MANUAL

Model: G300PUM for radio control Boat



! WARNING !

- This engine is designed for radio controlled boat use.
- When replacing parts, use only parts which have been certified by Zenoah.
- Zenoah assumes that no responsibility for this engine that is modified or used for any other applications.
- Purchaser has all responsibilities against any laws and regulations existing in the country, Zenoah is exempt from such laws and regulations.
- Read and completely understand this OWNER'S MANUAL before operating this engine.

⚠ WARNING ⚠

The engine exhaust from this product contains chemicals known to the State of California to cause cancer, birth defects or other reproductive harm.

⚠ AVERTISSEMENT ⚠

Les échappements du moteur de ce produit contiennent des produits chimiques connus par l'Etat de Californie comme étant responsables de cancers, d'anomalies congénitales et d'autres atteintes à l'appareil reproducteur.

⚠ ADVERTENCIA ⚠

Los gases de escape del motor de este producto contienen sustancias químicas conocidas por el Estado de California como causantes de cáncer, malformaciones en recién nacidos y otros problemas de reproducción.

Contents

1. Safety Precautions	3	9. Engine Break-In.....	11
2. Engine Assembling.....	4	10. Operation.....	11
3. Engine Mounting.....	5	11. Maintenance.....	12
4. Screw Propeller	6	12. Special Tools.....	17
5. Fuel.....	7	13. Trouble Shooting	18
6. Starting	8	14. Parts List.....	20
7. How to Stop The Engine.....	8	15. Warranty.....	23
8. Carburetor Adjustment	9		

⚠ 1. Safety Precautions ⚠

- This manual describes the engine. For its mounting and control, see the instruction manual provided by model boat manufacturer.
- This engine is designed for model boat use. If it is used for any other purpose, we cannot be responsible for its reliability, safety and any laws/regulations in the country.
- Use genuine parts for replacement.
- Check the rotor and screw-propeller every time. If it is damaged, replace it with a new one.
- If the screw-propeller hit something while the engine is in operation, immediately stop the engine and check it.
- Start the engine on a flat surface without pebble stones.
- Never modify the rotor.
- Check the rotor. If it is damaged, replace it with a new one.
- When mixing the fuel, or operating the engine, carry it out in a well-ventilated place.
- To prevent electrification, never touch the high-tension wire of the spark plug during operation.
- The engine metal parts can burn your skin. Never touch the engine and muffler during operation or right after stopping the engine.

2. Engine Assembling

The carburetor and air-funnel are not assembled at factory.

Make sure that the assembling for such parts are done according to the Fig.1.

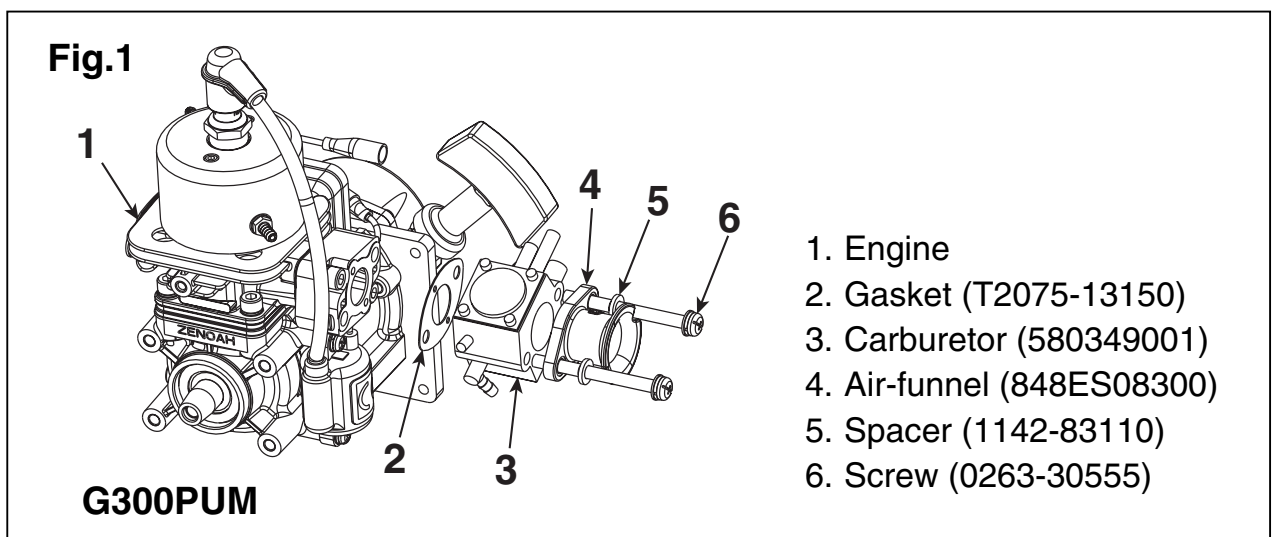

CAUTION

Make sure that gasket and carburetor are mounted as described in fig.1.

The engine does not start if carburetor is mounted upside down position.

3. Engine Mounting

Make sure that the engine is to be mounted according to the instruction manual provided by model boat manufacturer.

In case such instruction manual is not available, make sure that the engine should be mounted at least by 4 points both at engine's PTO side and recoil starter side.

[Note]

1) **Be sure to set flat washers or metal plates on the reverse side of the mount to prevent bolts from sinking into the mount.**

Be sure to check if the bolts are securely fastened.

2) **The fuel head between carburetor and the bottom of fuel tank must be less than 100 mm (4 inches)**

4. Screw-Propeller

The exhaust system (e.g., muffler) is not equipped with this engine as standard. When you select the exhaust system, check the engine speed (rpm) when the maximum output is generated by using the exhaust system you are going to select. And then decide the appropriate screw-propeller that would meet such engine speed (rpm) that the exhaust system requires.

In general, standard size of the screw propeller (Surface prop type) are as follows:

Diameter (mm)	Pitch ratio (mm)
65 ~ 75	1.9 ~ 1.4

5. Fuel

- Mixed gasoline (octane over 90) and high grade 2 cycle engine oil (mixing use type; JASO:FC grade or ISO: LEGC grade) at mixing ratio 25 : 1.
- The mixing ratio is according to the oil recommendation.

[NOTE]

1) Gasoline may contain maximum of 10% Ethanol (grain alcohol) or up to 15% MTBE (Methyl tertiary-butyl ether).

Gasoline containing Methanol (Wood Alcohol) is NOT approved.

2) Gasoline is very flammable. Avoid smoking, bringing any fires near fuel.

3) To prevent all possible problems on fueling system, make sure to use the fuel filter which has more than 300 mesh or equivalent and gasoline proof rubber pipe or equivalent.

Incorrect fuel filter use causes engine trouble like carburetor's fuel passage stuffing or piston surface scratching etc.

6. Starting

- How to start
 - a. Put fuel into the fuel tank.
 - b. While holding the equipment, pull out the starter rope swiftly.
 - c. In cold-starting, when the engine doesn't start. Partially choke the air-intake of carburetor by finger to make engine fire.

7. How to Stop The Engine

For stopping the engine, the black lead wire from the coil should be grounded to the engine body, or the throttle valve should be closed completely.

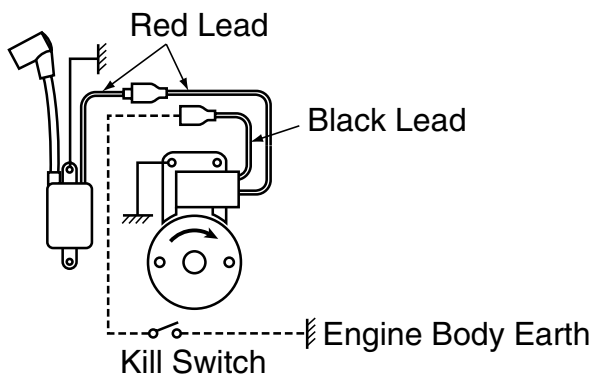

8. Carburetor Adjustment

The carburetor is provided with 3 adjust screws they may need a little adjustment depending on the temperature, atmospheric pressure (altitude), etc. of the area where the engine is used. Start the engine without making any adjustments. Make readjustments only when the engine shows any mal-running.

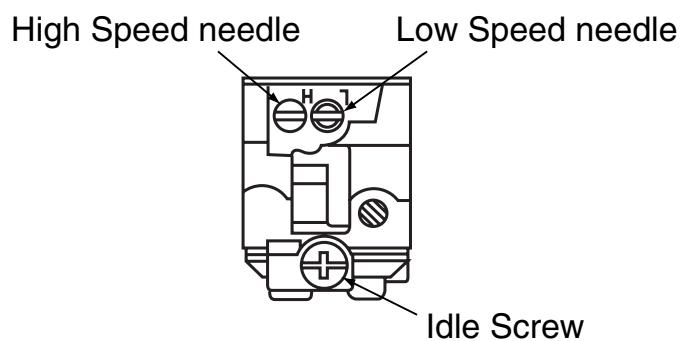

Standard opening of each needle as follows;

H	L
$1 \frac{5}{8} \pm \frac{1}{4}$	$1 \frac{1}{8} \pm \frac{1}{4}$

8. Carburetor Adjustment

Idle Screw:

Turning this screw clockwise increases the idling R.P.M. Turning it counterclockwise decreases the idling R.P.M

Low Speed needle:

This is the fuel adjust screw (not the air screw). Turning this needle clockwise makes the mixture gas leaner and turning it counterclockwise makes it richer. Set this needle at a position which is 1/4 open from best mixture (maximum R.P.M.) position.

High Speed needle:

Turning this needle clockwise makes the mixture gas leaner and turning it counterclockwise richer. Set this needle at a position which is 1/8~1/4 open (counter clockwise) from the maximum R.P.M. position.

CAUTION

- 1. Do not tighten the High and Low Speed needles too firmly.**
- 2. When the unit has just started and the engine is not warm enough, there may be insufficient acceleration and the engine may be stopped. Be sure to perform idling before operation.**

9. Engine Break-In

No specific break-in is required.

The engine is gradually broken-in as it is used and the output is also gradually increased.

For checking the whole conditions of the boat, it may be better to operate the engine at slow RPM for 1/3 tank and mid-high RPM for 2/3 tank.

10. Operation

- The engine is already tuned up to get high performance, and needs correct maintenance to keep such high performance.
- The details of operating model boat shall be provided by model boat manufacturer.
- Always keep the engine well according to the Maintenance clause described in this owner's manual.

11. Maintenance

1) MAINTENANCE CHART

Items	Action	Before Use	Every 25 hours	Every 100 hours	Note
Leakage, Damage/Crack	Check	✓	✓	✓	
Idling Speed	Check/Adjust	✓	✓	✓	
Spark Plug(gap)	Check/Adjust		✓	✓	Replace if necessary
Cylinder(barrel)	Check/Cleaning		✓	✓	↑
Piston, Ring	Check/Cleaning		✓	✓	↑
Muffler & Bolt	Check/Cleaning	✓	✓	✓	↑
Bearings	Check/Cleaning		✓	✓	↑
Crank Shaft	Check/Alignment			✓	↑
Rotor	Check		✓	✓	↑
Water Jacket	Check/Leakage	✓	✓	✓	↑

11. Maintenance

2) Specifications & Technical Data

ITEMS		SPECIFICATIONS
Engine model		G300PUM
Type		Water Cooled
Bore x stroke	(mm)	36 x 29
Displacement	(cm ³)	29.5
Effective Compression Ratio		8.6
Carburetor	type	Walbro WT-1048
	Venturi (mm)	ø13.5
Air funnel		—
Starting		Recoil Starter
Ignition	type	CDI
	BTDC (°/rpm)	30/7000
Sparkplug	STD	RZ7C
	Option	CMR6H/7H
Idle Speed	(rpm)	3500
Weight	(kg)	1.57

Specifications are subject to change without notice.

11. Maintenance

3) MAINTENANCE SPECIFICATIONS

	Items	G300PUM		Measuring Device	Remarks
		Standard	Limit		
Cylinder	Bore (mm)	ø36	Plating damaged	Eye Checking	
Piston	Diameter (mm)	ø35.97	ø35.87	Micro Meter	At the skirt end and the right angle to the piston pin.
	Piston Ring Groove width (mm)	1.01	1.11	Thickness Gauge	
	Piston Pin Hole (mm)	ø8.01	ø8.05	Cylinder Gauge	
	Clearance between Piston and Cylinder (mm)	0.03~0.06	0.15	Micro Meter Cylinder Gauge	
	Clearance between Groove and Piston Ring (mm)	0.02~0.04	0.1	Thickness Gauge	
Piston Ring	End Gap (mm)	0.05~0.25	0.5	Thickness Gauge	When inserted in a new cylinder.
	Width (mm)	0.98	0.93	Micro Meter	
	Piston Pin Diameter (mm)	ø8	ø7.98	Micro Meter	
	Connecting Rod Small end (mm)	ø11	ø11.05	Cylinder Gauge	
	Crankshaft Dia. at Main Bearing (mm)	ø12	ø11.98	Micro Meter	
	Eccentricity (mm)	—	0.07	Dial Gauge	
	Axial Play (mm)	—	0.5	Thickness Gauge	
	Main Bearing	—	Gritty or Feels Flat Spot	—	

11. Maintenance

4) CARBURETOR

Items	Unit	Standard	Measuring Device
Metering Lever set	mm	1.65 ± 0.16	Vanier
Inlet Valve Opening Pressure	MPa	0.16~0.26	Leak Tester
	kg/cm ²	1.6~2.6	
Inlet Valve Closing Pressure	MPa	0.08~0.18	Leak Tester
	kg/cm ²	0.8~1.8	

5) IGNITION SYSTEM

Items		Standard	Limit	Measuring Device	Remarks	
Spark Plug Air Gap (mm)		0.6~0.7	0.7	Thickness Gauge		
Ignition Coil/Rotor Air Gap (mm)		0.3	0.4	Thickness Gauge		
Coil Resistance (Ω)	Source Coil	1160-71211	∞ / 185Ω	—	Volt Meter	Coil core – Red wire / Coil core – Black wire
		2629-71210	∞ / 255Ω			Coil core – Red wire / Coil core – Black wire
	Ignition Coil	2629-71311	2.1kΩ	—	Volt Meter	Sparkplug wire – Red wire
			0.1 Ω	—		Red wire – Earth core
			2.1 kΩ	—		Sparkplug wire – Earth core

11. Maintenance

6) TIGHTENING TORQUE

Items	Screw Size	Standard		Limit		Remarks
		N·m	kg·cm	N·m	kg·cm	
Carburetor	M5 (P=0.8)	3.4	35	2.9~3.9	30~40	
Insulator	M5 (P=0.8)	4.4	45	3.9~4.9	40~50	
Rotor	M8 (P=1.0)	12.7	130	9.8~14.7	100~150	
Cylinder	M5 (P=0.8)	6.9	70	4.9~8.8	50~90	
Crankcase	M5 (P=0.8)	5.9	60	4.9~6.9	50~70	
Spark Plug	M10 (P=1.0)	10.8	110	8.8~12.8	90~130	
Muffler	M5 (P=0.8)	8.8	90	6.9~9.8	70~100	
IG Coil	M4 (P=0.7)	1.8	18	1.5~2.0	15~20	
SO Coil	M4 (P=0.7)	1.8	18	1.5~2.0	15~20	
Recoil Starter	M4 (P=0.7)	1.8	18	1.5~2.0	15~20	
Water Jacket	M3 (P=0.5)	1.5	15	1.0~2.0	10~20	
Mount Plate	M5 (P=0.8)	3.9	40	3.4~4.4	35~45	

12. Special Tools

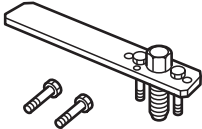
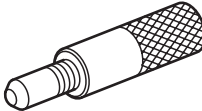
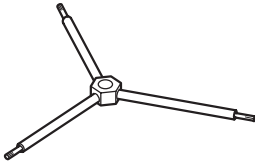
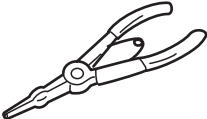
	Part Name	Part No.	External Appearance	Usage
1	Puller Assy	577409701		To remove rotor.
2	Piston Stopper	4810-96220		To hold crankshaft when disassembling/assembling the rotor.
3	Hex Wrench	3304-97611		For socket screw of 4mm, 5mm and 6mm.
4	Snap Ring Pliers	5500-96110		To remove snap ring.

13. Trouble Shooting

1) ENGINE DOES NOT START

Description	Cause	Countermeasure
No spark in the spark plug		
Spark Plug	1. Wet spark, plug electrodes	Make them dry
	2. Carbon deposited on the electrodes	Cleaning
	3. Insulation failure by insulator damage	Exchange
	4. Improper spark gap	Adjust to 0.6~0.7mm
	5. Burn out of electrodes	Exchange
Magneto	1. Ignition coil inside failure	Exchange
	2. Damaged cable sheath or disconnected cable	Exchange or repair
Switch	1. Switch is OFF	ON the switch
	2. Switch failure	Exchange
	3. Primary wiring earthed	Repair
Sparks appear in the spark plug		
Compression & fueling is normal	1. Over sucking of fuel	Drain excess fuel
	2. Too rich fuel	Adjust carburetor
	3. Overflow	Carburetor adjust or exchange
	4. Clogging of air cleaner	Wash with mixed gasoline
	5. Faulty fuel	Change with proper fuel
Fueling normal but poor compression	1. Worn out cylinder, piston, or piston ring	Exchange
	2. Gas leakage from cylinder and crank case gasket	Apply liquid gasket and reassemble.
No fuel supply	1. Choked breather air hole	Cleaning
	2. Clogged carburetor	Cleaning
	3. Clogged fuel filter	Exchange fuel filter

13. Trouble Shooting

2) LACK OF POWER OR UNSTABLE RUNNING

Description	Cause	Countermeasure
	1. Air penetration from fuel pipe joints, etc	Secure connection
	2. Air penetration from intake tube joint or carburetor joint	Change gasket or tightening screws
	3. Water in fuel	Change with good fuel
	4. Piston start to seizure	Replace piston(and cylinder)
	5. Muffler choked with carbon	Cleaning
Overheating	1. Fuel too lean	Adjust carburetor
	2. Clogging of cylinder fin with dust	Cleaning
	3. Poor fuel quality	Exchange with proper fuel
	4. Carbon deposited in the combustion chamber	Cleaning
	5. Spark plug electrode red hot	Thoroughly clean, adjust spark gap [0.6~0.7(0.023~0.028in)]
Others	1. Dirty air cleaner	Wash with mixed gasoline
	2. Over loading	Reduce load

14. Parts List

KEY#	PART NUMBER	DESCRIPTION	Q'TY/ UNIT	REMARKS	KEY#	PART NUMBER	DESCRIPTION	Q'TY/ UNIT	REMARKS
1	577916501	CYLINDER	1		35	848ESZ7510	RECOIL ASSY	1	
2	577901901	JACKET	1		36	1850-75130	• SPRING, spiral	1	
3	07851-00515	JOINT	2		37	848E4075C0	• REEL	1	
4	07000-13042	O-RING 3x42	1		38	848E4075G0	• SPRING	1	
5	T2076-12320	O-RING 1.5x15.5	1		39	848E4075D0	• CAM PLATE	1	
6	1160-12330	BOLT M3x8	2		40	848E4075E0	• SCREW	1	
7	580706001	GASKET, BASE	1		41	848E4075F0	• ROPE	1	
8	3310-12281	BOLT M5x20	6		42	1140-75320	• KNOB	1	
9	T2075-13150	GASKET, insulator	1		43	848H7075G1	• ROPE STOPPER	1	
10	1148-13162	INSULATOR	1		44	580447901	PLATE	1	
11	T2075-14120	GASKET, carburetor	1		45	0260-30420	SCREW M4x20	4	
12	T2075-21100	CRANKCASE COMP.	1		46	1000-43240	KEY	1	
13	-	CRANKCASE (R)	1		47	114043250	SHIM	0-3	
14	-	CRANKCASE (F)	1		48	1160-71211	COIL (red)	1	
15	2629-21130	PIN	3		49	1155-71110	ROTOR	1	
16	T2075-21140	GASKET	1		50	0260-30422	SCREW M4x22	2	
17	2169-21210	SEAL 12x22x7	1		51	0263-30414	SCREW M4x14	2	
18	1155-21240	BEARING	2		52	T2075-72210	PLUG CAP	1	
19	04065-02812	SNAPRING	1		53	1400-72121	SPRING	1	
20	1850-21220	SEAL 12x28x7	1		54	2629-71311	COIL	1	
21	01252-30530	BOLT M5x30	4		55	3699-91809	SPARK PLUG RZ7C	1	
22	574791001	PISTON	1		56	0263-30555	SCREW M5x55	2	
23	574791101	RING	1		57	1142-83110	SPACER	1	
24	574791201	PISTON PIN	1		58	848ES08300	FUNNEL	1	
25	1260-41320	SNAP RING	2		59	580349001	CARBURETOR ASSY	1	WT-1048
26	5500-41410	BEARING	1		60	1140-13141	GASKET, muffler	1	
27	1101-41340	WASHER	2		61	T3039-91310	SOCKET	1	
28	579245001	CRANKSHAFT COMP.	1		62	115487926	MANUAL	1	
29	1155-74110	PLATE, mount	1		63	3699-91975	SPARK PLUG CMR6H	1	Option
30	0262-10516	SCREW M5x16	3		64	3699-91867	SPARK PLUG CMR7H	1	Option
31	848ESZ7520	PULLEY	1		65	577409701	PULLER ASSY	1	Option
32	848ESZ75R0	• RATCHET	2		66	4810-96220	STOPPER	1	Option
33	1850-75230	• SPRING	2						
34	1034-72180	• E-RING	2						

14. Parts List

KEY#	PART NUMBER	DESCRIPTION	Q'TY/ UNIT	REMARKS
1	580349001	CARBURETOR ASSY	1	
2	3306-81380	• SCREEN	1	
3	2630-81120	• COVER	1	
4	3310-81130	• SCREW	1	
5	3304-81140	• GASKET	1	
6	1172-81150	• DIAPHRAGM	1	
7	3356-81310	• VALVE, INLET	1	
8	2850-81290	• GASKET, METERI	1	
9	848HE081K0	• DIAPHRAGM	1	
10	1488-81370	• SPRING	1	
11	3310-81280	• COVER	1	
12	3310-81240	• SCREW	1	
13	3310-81250	• PIN	1	
14	3310-81230	• LEVER	1	
15	1480-81420	• PLUG	1	
16	3356-81340	• VALVE, THROTTLE	1	
17	2880-81470	• SCREW	1	
18	2670-81410	• RETURN SPRING	1	
19	2609-81370	• SHAFT-A	1	
20	3350-81380	• SPRING	1	
21	2630-81330	• SCREW	1	
22	1148-81390	• RING	1	
23	1491-81160	• SPRING	1	
24	579047501	• NEEDLE, IDLE	1	
25	3080-81320	• SPRING	1	
26	579047601	• NEEDLE, HIGH SPEED	1	
27	3310-81351	• SCREW ASSY	4	
28	3360-81440	• PLUG	1	
29	3304-81441	• RING	1	
30	3304-81450	• SCREEN	1	

15. Warranty

WARRANTY TERMS

1) Scope of Application

This engine manufactured by Husqvarna Zenoah Co., Ltd. (herein after “Zenoah”). And sold to the user directly or through distributor/manufacture, shall entitle to be covered by this warranty.

2) Limits of Warranty

Zenoah warrants that;

1. The quality disclosed in the specifications.
2. The engine which shall be considered defective by Zenoah, caused by material or production fault.

3) Limits of Compensation

1. Zenoah compensates such quality, material and production faults by repairing or replacing through distributor/manufacture.
2. Zenoah shall not compensate any other accompanied or benefit losses caused to user and distributor/manufacture by such faults and through repairing or replacing.

4) Term of Warranty

Three (3) months after purchased by end-user subject to 12 months from produced month.

5) Exempt from Warranty

Zenoah shall not warrant this engine even if the fault has been caused during the period of terms of Warranty, in case that.

1. Any faults, failures caused from neglect of proper operation and maintenance described in OWNER’S MANUAL.
2. Any modification not approved by Zenoah.
3. Normal abrasion and deterioration.
4. Consuming parts.
5. Using any parts which have not been certified by Zenoah.
6. Add-on or modified use.



Husqvarna Zenoah Co., Ltd.

Head Office : 1-9 Minamidai, Kawagoe-city, Saitama, 350-1165 Japan

Phone: (+81)49-243-1115 Fax: (+81)49-243-7197